



**PE PIPE PEELERS / SCRAPERS
TECHNICAL INFORMATION**

NO. KMC-22

REV B

DATE 20JAN2022

PAGE 1 OF 15



Split Peeler



Pipe Peeler/Scraper



**Tapping Tee Outlet
Peeler**



**Aldyl-A Tapping Tee
Repair Peeler**

Table of Contents

1. PURPOSE 2

2. SCOPE 2

3. DEFINITIONS 2

4. REFERENCES 2

5. RISKS 2

6. ENVIRONMENTAL, HEALTH & SAFETY (EHS) 2

7. GENERAL INFORMATION, GUIDELINES, AND CAUTIONS 3

8. SPLIT PEELER 4

 8.1. Ordering Information 4

 8.2. Operating Instructions 5

 8.3. Technical Data 7

 8.4. Replacement Parts Sizes NPS 8 and Smaller 7

 8.5. Replacement Parts Size NPS 12 9

 8.6. Changing the Cutting Blade 10

9. SURFACE PEELER 11

 9.1. Ordering Information 11

 9.2. Operating Instructions 11

 9.3. Technical Data 12

 9.4. Replacement Parts Sizes NPS 1/2 CTS to 2 IPS 12

10. TAPPING TEE OUTLET PEELER 13

 10.1. Ordering Information 13

 10.2. Operating Instructions 13

 10.3. Technical Data 13

 10.4. Replacement Parts 14

11. DUPONT ALDYL-A TEE OUTLET REPAIR PEELER 14

 11.1. Ordering Information 14

 11.2. Operating Instructions 14

 11.3. Replacement Parts 15



PE PIPE PEELERS / SCRAPERS TECHNICAL INFORMATION

NO. KMC-22

REV B

DATE 20JAN2022

PAGE 2 OF 15

1. PURPOSE

- 1.1. This document provides the ordering, instructions for use, technical information, and service requirements for the Kerotest Manufacturing Corp. Polyethylene Pipe and Fitting Scraper and Peeler products. Scraping and peeling tools remove the contamination and oxidation layer from the pipe or fitting.
- 1.2. Scraping and peeling is an integral step in the process of performing electrofusion of pipe and fittings. For full details on the process of electrofusion, refer to document K-1412.

2. SCOPE

- 2.1. This procedure applies to all peelers and scrapers supplied by Kerotest. To ensure these products live up to all expectations, it is important to read and comply with this instruction manual before attempting to scrape or peel pipe or fittings prior to making any electrofusion joints.
- 2.2. This manual is intended to provide a general introduction to the tools and steps required for making quality peelings/scrapings. Kerotest assumes no liability in connection with the data contained within this document and all data is accepted at the user's risk

3. DEFINITIONS



- **General Advisory Marking** – for information or operational procedures, order of operation, etc.



- **Caution Marking** – note designates an action or step that may result in personal injury or death or equipment/property damage. Personnel performing activities should be fully aware of the hazards and take necessary steps to prevent any injuries, damage, or unsafe operating/repair conditions.

4. REFERENCES

- K-1013-NP *Aldyl-A Tapping Tee Repair Kit Installation Instructions*
- K-1412 *INNOGAZ Electrofusion Installation Procedure*
- 49 CFR § 192.285 Code of Federal Regulations, Title 49, Part 192 *Plastic pipe: Qualifying persons to make joints*

5. RISKS

- 5.1. Improper scrapping can directly affect the quality of the electrofusion joint.
- 5.2. A poor-quality electrofusion joint may fail prematurely, resulting in injury or death along with damage to materials and property.

6. ENVIRONMENTAL, HEALTH & SAFETY (EHS)

- 6.1. Follow all safety guidelines and use the necessary Personal Protective Equipment (PPE).
- 6.2. Blades on the peelers are sharp and should be handled with care.
- 6.3. Avoid pinch points on the tool.



PE PIPE PEELERS / SCRAPERS
TECHNICAL INFORMATION

NO. KMC-22

REV B

DATE 20JAN2022

PAGE 3 OF 15

7. GENERAL INFORMATION, GUIDELINES, AND CAUTIONS

7.1. Qualified Operators: The operators performing scraping and peeling, and the eventual electrofusion of the fittings, should be qualified in accordance with 49 CFR § 192.285 and familiar with their tools.



7.2. **Caution:** When installing electrofusion couplings, ensure the gas flow is shut-off completely and that the gas concentration in the surrounding is below critical level. When performing the scrapping or peeling process of electrofusion tapping tees or branch saddles (BS) it is not necessary to shut off the gas flow. For repair saddles (RS), if the area of pipe is leaking gas make SURE the gas flow has been shut off.

7.3. Clean the pipe and fitting with isopropyl alcohol - IPA (94% or greater concentration) prior to scraping according to K-1412. Make sure there is no dirt or any other debris in the pipe section to be peeled.

7.4. Scrapers should remove a minimum of .007" but never more than 10% of the wall thickness.



To verify the correct amount of pipe has been removed, a caliper can be used to measure the removed ribbon.

7.5. Scrap/peel beyond the edge of the electrofusion fitting to assure adequate surface preparation.

7.6. Tools Maintenance



7.6.1. Tools should be inspected before use and in good working order and clean condition. Always keep the Split Peeler in good working order by cleaning it after each use.

7.6.2. Worn or damaged tools should be repaired or replaced before use.

7.6.3. Tools should be stored carefully so that damage when not in use is minimized.

7.6.4. It is recommended to periodically measure the amount of material scrapped or peeled during operation.

7.7. The use of a pipe surface witness mark tool can be a visual indicator that adequate scraping/peeling has occurred. If the marks are present after scraping, not enough material was removed.

7.8. Do not use a knife, sandpaper, or abrasive material to scrape PE pipe. Hand scrapers are generally not recommended. Avoid touching or otherwise contaminating the scraped/peeled surfaces.



7.9. Visually inspect the finished surface following scraping/peeling. The surface should be relatively smooth without ridges or marks caused by defective or worn tools.



**PE PIPE PEELERS / SCRAPERS
TECHNICAL INFORMATION**

NO.	KMC-22
REV	B
DATE	20JAN2022
PAGE	4 OF 15

8. SPLIT PEELER

8.1. Ordering Information

Table 1 - Ordering Details

NPS Size	Part No
1-1/4 IPS	88414677
2 IPS	88414529
3 IPS	88414685
4 IPS	88414693
6 IPS	88414701
8 IPS	88280551
12 IPS	88280585

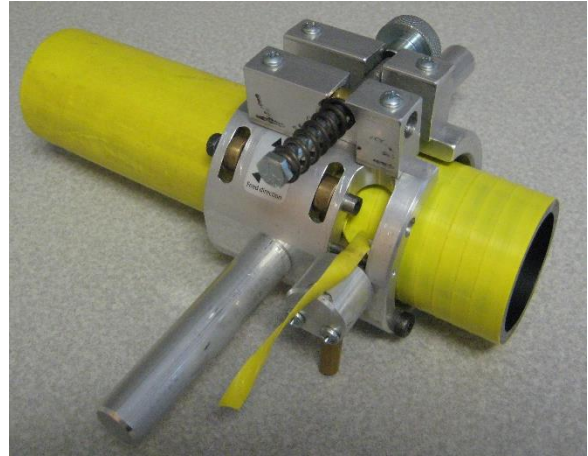

Replacement Blades	
1-1/4, 2	88280559
3, 4	88280561
6, 8, and 12	88280563



Carrying Case for Peelers	
1-1/4, 2, 3, and 4	88416367
6, 8	88416375

8.2. Operating Instructions

8.2.1. Components of Split Peeler

1. Thumb Screw
2. Direction of Rotation
3. Housing
4. Closing Mechanism
5. Cutting Blade Mechanism
6. Shoulder Bolt
7. Roller

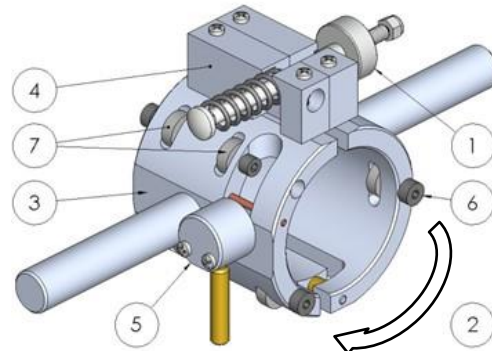

8.2.2. General Guidelines:

- Always clean the pipe prior to peeling. Make sure there is no dirt or any other debris on the pipe section to be peeled.
- Always keep the split peeler in good working order by cleaning it after each use. Store the peeler in a proper manner to prevent damage to the blade and mechanisms to ensure a long lifetime.
- Keep split peeler from moisture to prevent corrosion which may cause restriction of moving parts.
- Compressed air may be useful in removing dirt from the moving parts.
- Factors such as dirt can reduce the lifetime of the cutting blade, and it may have to be replaced.
- Be aware that the cutting blade is sharp and can cause injury if handled improperly!
- The warning, caution, and instructions discussed in this manual cannot cover all possible conditions and situations that may occur. **It must be understood by the operator that common sense and caution are factors which cannot be built into this product. Operators must maintain a safe working environment.**



8.2.3. Operating the Tool

1. Open the peeler and place it over the pipe section to be peeled, observing the position of the cutting blade on the pipe. The brass lever can be used to retract the blade to allow precise positioning (Figure 1)
2. Tighten the thumb screw to the stop to securely attach the peeler to the pipe. Only tighten the screw far enough to eliminate any rocking or play of the peeler on the pipe. DO NOT overtighten! (Figure 2)



1



2

3. Turn the peeler in the direction indicated by the label on the housing. The peeler is self-feeding and will move in the direction indicated on the picture (Figure 3)
4. Continue turning the peeler until an adequate length of pipe has been peeled.
5. While turning the peeler, be sure the pipe shavings don't get between the pipe and peeler.
6. Open the peeler by loosening the thumb screw and remove it from the pipe.
7. Before proceeding to electrofusion, inspect the peeled surface to confirm that all oxidation has been removed from that section of the pipe. It is the operator's responsibility to ensure the pipe has been properly cleaned before electrofusion.

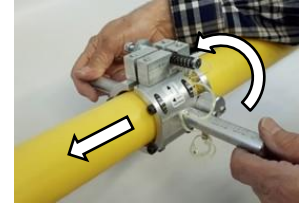

BEFORE EACH USE

- Check that the cutting blade can move freely in the cap by depressing the brass lever and watching the blade retract.

EVERY 50 PEELS (adjust this interval as needed based on your operating conditions)

- Apply a drop of light oil to the threads of the thumb screw to maintain free movement and prevent corrosion.
- Inspect the cutting edge of the blade for any chips and signs of wear. Replace if necessary.
- Check that all rollers are functional by turning them with your fingers. Any rollers that cannot be moved with light finger pressure should be replaced.
- The rollers are lubricated at the factory and should not require any lubrication during their lifetime



**PE PIPE PEELERS / SCRAPERS
TECHNICAL INFORMATION**

NO. KMC-22

REV B

DATE 20JAN2022

PAGE 7 OF 15

8.3. Technical Data

Table 2 - Scrape Depth - Scraper and Blade Dimensions - Weight for NPS Sizes 1-1/4 IPS to 8 IPS

Peeler	Scrape Depth		Housing Diameter (inch)	Overall Diameter (inch)	Cutting Blade		Weight (lbs.)
	Max (inch)	Nominal Range (inch)			Width (inch)	Length (inch)	
1-1/4	.012	.007-.010	2.677	9.65	.63	.87	1.87
2	.012	.007-.010	3.268	10.04	.63	.87	1.87
3	.018	.007-.012	4.449	11.42	.63	1.02	2.53
4	.018	.007-.012	5.472	13.98	.63	1.02	2.97
6	.020	.007-.014	7.874	16.54	.75	1.22	5.51
8	.020	.007-.014	9.843	18.50	.75	1.22	7.27

- All split peelers are made of aluminum
- Cutting blades are made of high strength steel and are field replaceable
- Minimum recommended scraping depth for acceptable pipe preparation is .007.
- Consult EF fitting manufacturer's information for recommended scrape depth by fitting size

8.4. Replacement Parts Sizes NPS 8 and Smaller

Sizes— NPS 1-1/4 IPS to 8 IPS

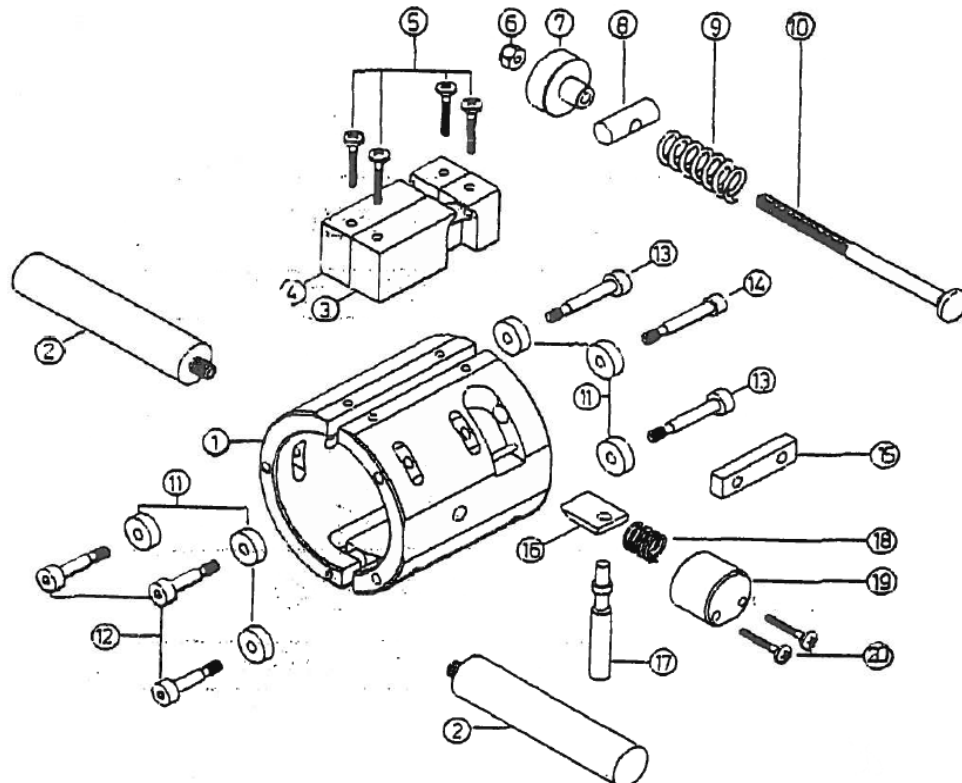



**PE PIPE PEELERS / SCRAPERS
TECHNICAL INFORMATION**

NO. KMC-22

REV B

DATE 20JAN2022

PAGE 8 OF 15

Table 3 - Split Peeler Replacement Parts List

Item	Description	1-1/4 IPS	2 IPS	3 IPS	4 IPS	6 IPS	8 IPS
1	HOUSING	N/A	N/A	N/A	N/A	N/A	N/A
2	HANDLE	88415443	88415443	88415443	88415443	88412110	88412110
3	CLOSING MECH. FRONT	88416664	88416664	88416664	88416680	88416680	88416680
4	CLOSING MECH. BACK	88416672	88416672	88416672	88416698	88416698	88416698
5	SCREW CLOSING MECH	88415114	88415114	88415112	88415112	88415112	88415112
6	LOCK NUT	88415468	88415468	88415468	88415468	88415468	88415468
7	THUMB SCREW	88415476	88415476	88415476	88415476	88415476	88415476
8	PIN CLOSING MECH	88415484	88415484	88415484	88415484	88415484	88415484
9	SPRING CLOSING MECH	88415492	88415492	88415492	88415492	88415492	88415492
10	BOLT (LG) CLOSING MECH	88415500	88415500	88416706	88416706	88416706	88416706
11	ROLLER - BRASS ***1	88414818	88416961	88414834	88414834	88414842	88414859
11	ROLLER - STEEL ***2	88416961	88416961	88416961	88417035	88417035	88417035
12	SHOULDER BOLT SHORT	88415526	88415526	88415526	88415526	88415526	88415526
13	SHOULDER BOLT LONG	88415534	88415534	88415534	88415534	88415534	88415534
14	SHOULDER BOLT	88415542	88415542	88416714	88416714	88416714	88416714
15	BLOCK GUIDE	X	X	88416722	88416722	88416722	88416730
16	BLADE	88280559	88280559	88280561	88280561	88280563	88280563
17	LEVER	88415559	88415559	88415559	88415559	88415559	88415559
18	SPRING FOR BLADE	88415567	88415567	88415195	88415195	88415195	88415195
19	CAP	88415575	88415575	88416748	88416748	88416748	88416748
20	SCREW FOR CAP	88415583	88415583	88416755	88416755	88416755	88416755

ROLLER REPLACEMENT

- ***1 SPLIT PEELERS that were manufactured with "BRASS ROLLERS" **MUST** always be re-fitted with replacement "BRASS" rollers for NPS sizes: 1-1/4 - 3 - 4 - 6 - 8
 Note: The **only exception** is the NPS 2 Split Peeler size. The STEEL Roller P/N 88416961 will only work on the NPS 2 IPS Split Peeler
- ***2 New SPLIT PEELERS with STEEL ROLLERS must always be re-fitted with Steel Rollers. These Split Peelers will be marked with Peeler size and a suffix "SR".
 Example: the stamping will show **(2IPS-SR)** which denotes a Split Peeler for NPS 2 IPS PE Pipe with STEEL ROLLERS

8.5. Replacement Parts Size NPS 12

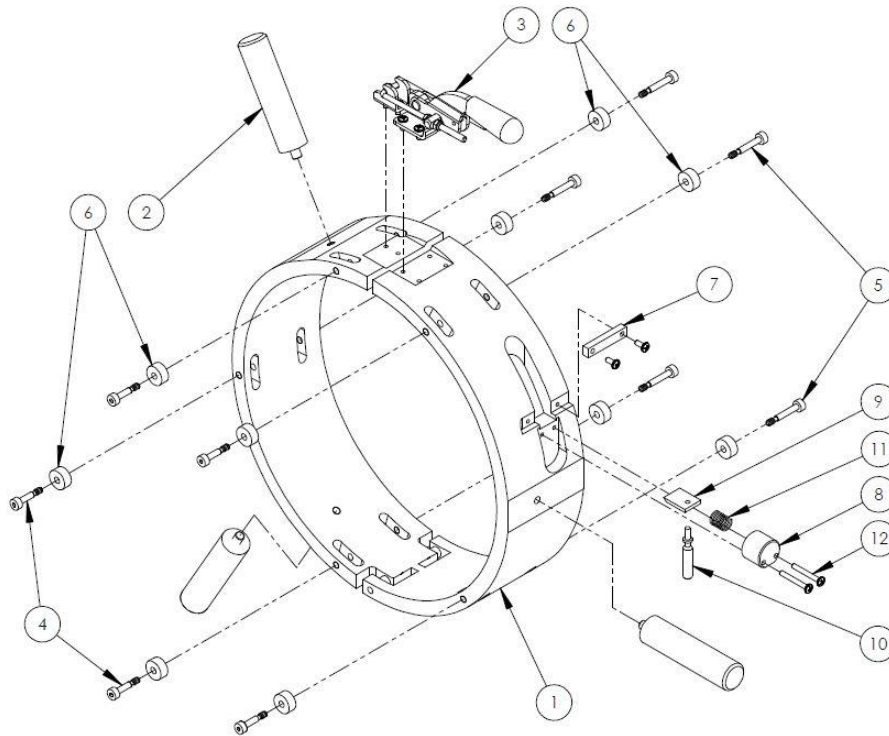

Table 4 - Split Peeler Replacement Part Numbers for NPS 12

Item	Description	Part No
1	HOUSING	N/A
2	HANDLE	88412110
3	CLOSING MECH. W/ LATCH PLATE & SCREWS	88416789
4	SHOULDER BOLT SHORT	88415526
5	SHOULDER BOLT LONG	88415534
6	ROLLER (BRASS)	88414860
7	BLOCK GUIDE	88416805
8	CAP	88416748
9	BLADE	88280563
10	LEVER	88415559
11	SPRING FOR BLADE	88415195
12	SCREW FOR CAP	88416755

8.6. Changing the Cutting Blade

Table 5 - Parts Identification

Item	Description
A	CAP
B	CUTTING BLADE
C	SPRING
D	LEVER
E	SCREWS

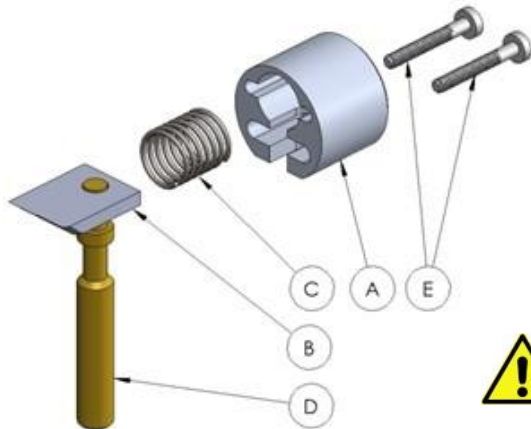

Caution: The blade is sharp and can cause injury if not handled carefully!

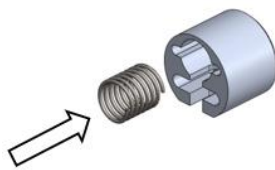

Fig 1

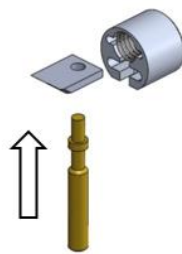

Fig 2



Fig 3



Fig 4

1. Remove the two screws (E) holding the cutter blade mechanism from the Split Peeler.
2. Insert the Spring (C) into the Cap (Fig 1).
3. Insert the Lever (D) into the hole in the Blade (B) (Fig 2).
4. Slide the Lever and Blade into the Cap and align both with the appropriate slots in the Cap (Fig 3).
5. Insert the Screws (E) (Fig 4).
6. Mount the entire assembly on the Split Peeler (Fig 5). On 3" to 8" Split Peelers, ensure that the brass block guide is adjusted to touch the top of the blade to eliminate excessive play, and that the mounting screws are tight.

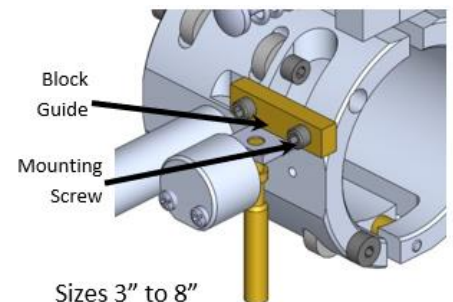
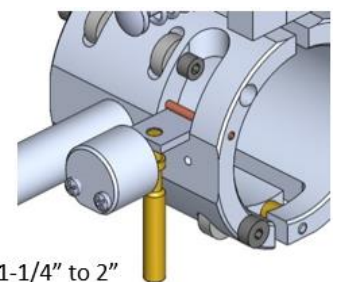

Fig 5



**PE PIPE PEELERS / SCRAPERS
TECHNICAL INFORMATION**

NO. KMC-22

REV B

DATE 20JAN2022

PAGE 11 OF 15

9. SURFACE PEELER

9.1. Ordering Information

Table 6 - Ordering Details

NPS Size	Part No
1/2 CTS	88280467
1/2 IPS	88280469
3/4 IPS	88280487
1 CTS	88280473
1 IPS	88280475
1-1/4 IPS	88280477
1-1/4 CTS	88280606
2 IPS	88280479

Replacement Blade	
1/2 - 2	88415955



9.2. Operating Instructions

1. Cut the PE Pipe squarely prior to scraping
2. The mandrel guide pin on the PE pipe peeler should be extended out beyond outlet hole
3. Push PE pipe end to be peeled onto the mandrel guide pin
4. Using the blade release lever, pull the cutting blade back (push lever down)
5. Turn PE pipe peeler a few revolutions, until the end of the pipe is in the middle of the cutting blade
6. Release the cutting blade release lever, and continue to turn the PE pipe peeler until the peeler stop is reached and the cutting blade no longer cuts into new PE pipe material
7. To prevent scoring of the peeled surface, depress the blade release lever to pull the cutting blade back, and remove the PE pipe from the peeler
8. Thread mandrel guide pin back to original position for next scraping





**PE PIPE PEELERS / SCRAPERS
TECHNICAL INFORMATION**

NO. KMC-22

REV B

DATE 20JAN2022

PAGE 12 OF 15

9.3. Technical Data

Table 7 - Scrape Depth, Scraper Dimensions, and Weight for Sizes NPS 1/2 CTS to 2 IPS

Peeler	Peeler Scrape		Housing Diameter (inch)	Overall Length (inch)	Weight (lbs)
	Depth (inch)	Length (inch)			
1/2 CTS	.007 - .010	1.299	1.811	3.071	.66
1/2 IPS	.007 - .010	1.181	1.969	2.953	.77
3/4 IPS	.007 - .010	1.496	2.087	3.465	.88
1 CTS	.007 - .010	1.614	2.087	3.346	.99
1 IPS	.007 - .010	1.614	2.362	3.504	1.10
1-1/4 IPS	.007 - .010	1.772	2.596	3.465	1.32
2 IPS	.007 - .010	2.205	3.346	3.819	2.20

9.4. Replacement Parts Sizes NPS 1/2 CTS to 2 IPS

Table 8 - Replacement Parts

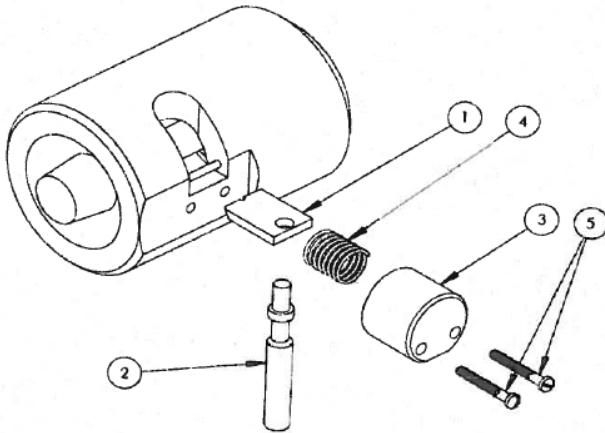

Item	Description	Part No
1	BLADE	88415955
2	LEVER	88415559
3	CAP	88415575
4	SPRING FOR BLADE	88415190
5	SCREW FOR CAP	88415583



Caution: The blade is sharp and can cause injury if not handled carefully!



**PE PIPE PEELERS / SCRAPERS
TECHNICAL INFORMATION**

NO. KMC-22

REV B

DATE 20JAN2022

PAGE 13 OF 15

10. TAPPING TEE OUTLET PEELER

10.1. Ordering Information

Table 9 - Ordering Details

NPS Size	Part No
1/2 CTS	88280401
1/2 IPS	88280397
3/4 IPS	88280395
1 CTS	88280399
1 IPS	88280393
1-1/4 IPS	88280550
1-1/4 CTS	88280589
2 IPS	88280520



Replacement Blades	
1/2 - 2	88280588

10.2. Operating Instructions

1. The mandrel guide pin on the Tapping Tee peeler should be extended out beyond the outlet hole of Tapping Tee peeler
2. Push the mandrel guide pin of the Tapping Tee peeler into the outlet of the Tapping Tee
3. Turn the PE Tapping Tee peeler until the peeler stop is reached and the cutting blade no longer cuts into new PE pipe material
4. Remove the PE Tapping Tee peeler from the Tapping Tee outlet
5. Thread mandrel guide pin back to original position for next scraping

10.3. Technical Data

Table 10 - Scrape Depth, Scraper Dimensions, and Weight for Sizes NPS 1/2 CTS to 2 IPS

Peeler	Peeler Scrape		Housing Diameter (inch)	Overall Length (inch)	Weight (lbs)
	Depth (inch)	Length (inch)			
1/2 CTS	.007 - .010	1.26	1.50	2.64	.44
3/4 IPS	.007 - .010	1.57	1.75	2.91	.55
1 CTS	.007 - .010	1.65	2.00	3.15	.84
1 IPS	.007 - .010	1.61	2.00	3.23	.79
1-1/4 IPS	.007 - .010	1.75	2.50	3.15	1.08
2 IPS	.007 - .010	2.32	3.25	3.86	1.43

10.4. Replacement Parts



Table 11 - Replacement Parts

Item	Description	Part No
1	BLADE	88280588
2	SCREW FOR BLADE	88417050



Caution: The blade is sharp and can cause injury if not handled carefully!

11. DUPONT ALDYL-A TEE OUTLET REPAIR PEELER

11.1. Ordering Information

Table 12 - Ordering Details

Size	Part No
Standard Neck (125)	88416226
Small Neck (40)	88416229

Replacement Blades	
All	88416229



11.2. Operating Instructions

11.2.1. Follow Kerotest procedure K-1013-NP



Aldyl-A Tapping Tee with a leaking cap



Removes material from the head of Aldyl-A Tapping Tee



PE PIPE PEELERS / SCRAPERS
TECHNICAL INFORMATION

NO. KMC-22

REV B

DATE 20JAN2022

PAGE 15 OF 15

11.3. Replacement Parts

Table 13 - Replacement Parts

Item	Description	Part No
1	BLADE (see note below)	88416229
2	SCREW FOR BLADE	88417050



11.3.1. Aldyl-A scrapers have 2x blades Side A & B

11.3.2. Note: Blades have four (4x) sides
and all four sides can be used



Caution: The blades are sharp and can cause injury if not handled carefully!

Revision History:

Rev	Date	Description	Author	Approval	Approval
A	12-JAN-2018	Field release. EAN S-1373	DT Frederick	CF Woolley	W Copeland
B	20-JAN-2022	Format update. Added sections 2 through 7. Updated Split Peeler information. EC S-1722	DT Frederick	Craig Larson 2022.01.21 13:41:54 -05'00'	Bill Copeland 2022.01.21 07:13:43 -05'00'

Kerotest Manufacturing Corp.
5500 Second Ave, Pittsburgh PA 15207 USA
P (412) 521-5942
www.kerotest.com email: sales@kerotest.com